

# RM 50T-2

## FISH MEAL PROCESSING

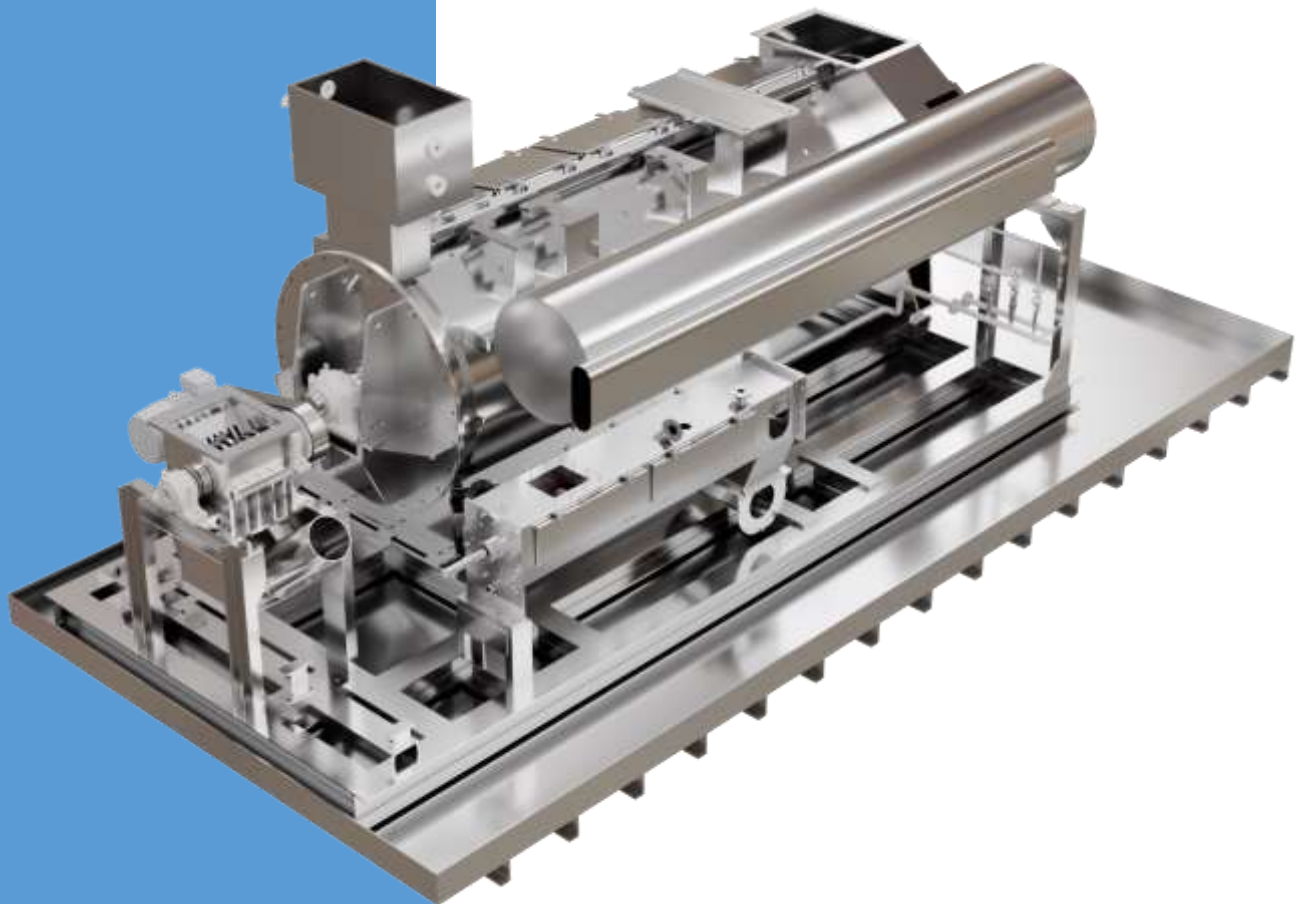

223, Gamcheonhang-ro, Saha-gu, Busan, South Korea, 49454

Fax: +82-51-2638-940

E-mail: [noatek1@gmail.com](mailto:noatek1@gmail.com)

**CEO KIM A.B.**

Phone: +82-10-5049-4892

## Technical data

OEM	RM Pusan Group
Equipment	The machine is using for the production of feed meal from fish waste and low-value fish species
Throughput rate	50 t/a day
Frame material	Boiler steel
Steam pressure requirement	7 bar
Power consumption	50 kWt
Electrical connection	3 Ph 380 VAC 50/60Hz
Dimensions of the machine	
Length	3838 mm
Width	3160 mm
Height	3291 mm
Weight	30 t

RM fish meal lines also includes models with throughput rate up to 30, 80 and 120 t / a day

---

Raw materials.....Processing.....End-product

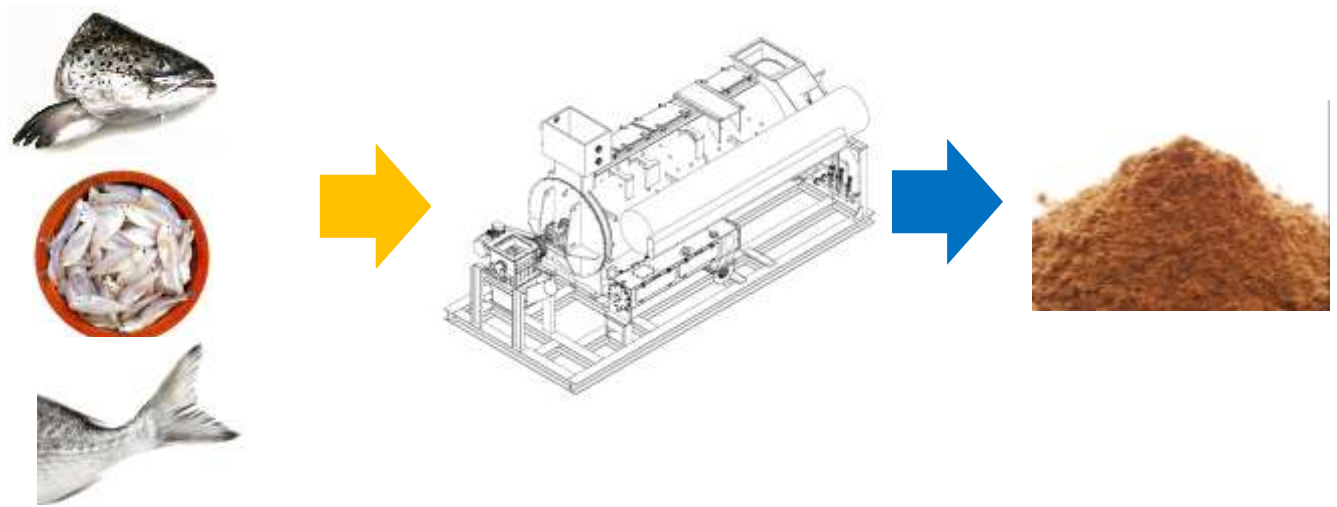

Dimensional drawing

