

RM 30T-S

FISH MEAL PROCESSING

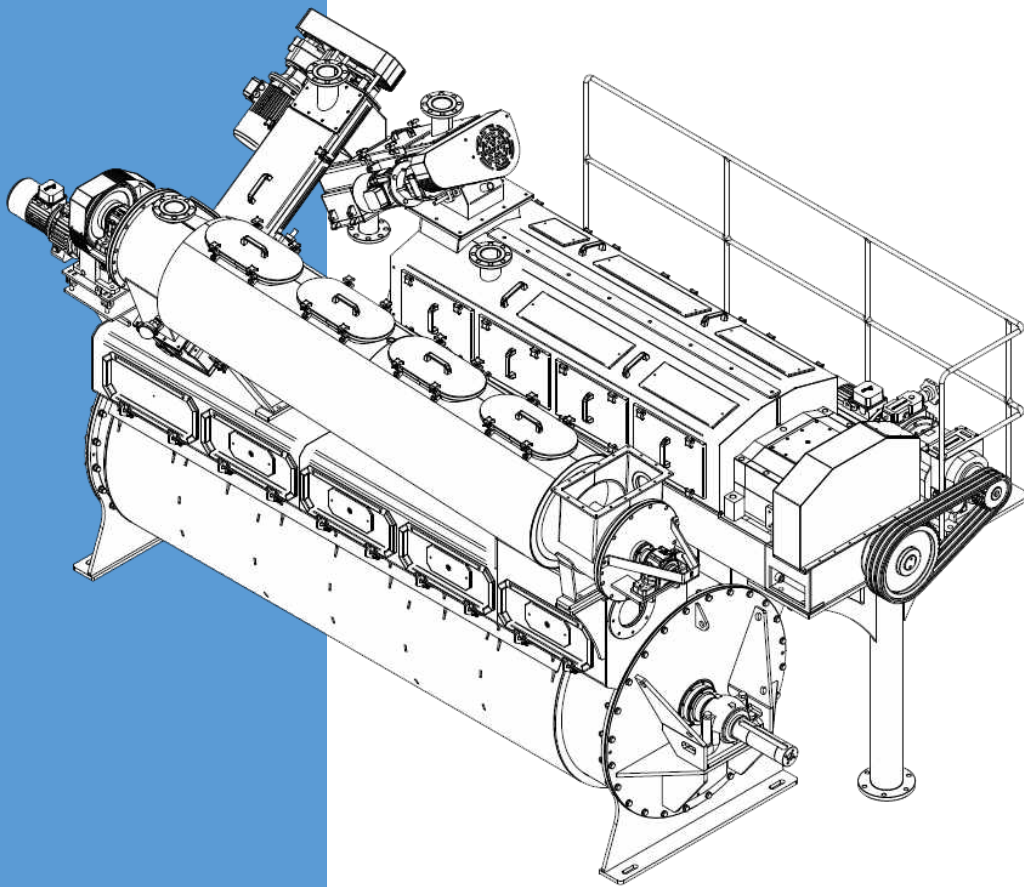

Technical data

OEM	RM Pusan Group
Equipment	The machine is using for the production of feed meal from fish waste and low-value fish species
Throughput rate	30 t/a day
Frame material	Stainless steel/Boiler steel
Steam pressure requirement	7 bar
Power consumption	22 kWt
Electrical connection	3 Ph 380 VAC 50Hz
Dimensions of the machine	
Length	4505 mm
Width	2341 mm
Height	2503 mm
Weight	10000 kg

RM T-S model line also includes models with throughput rate up to 50, 80, 120 t / a day

Raw materials.....Processing.....End-product



Dimensional drawing

