

# RM 2009

## CHECK SCALES

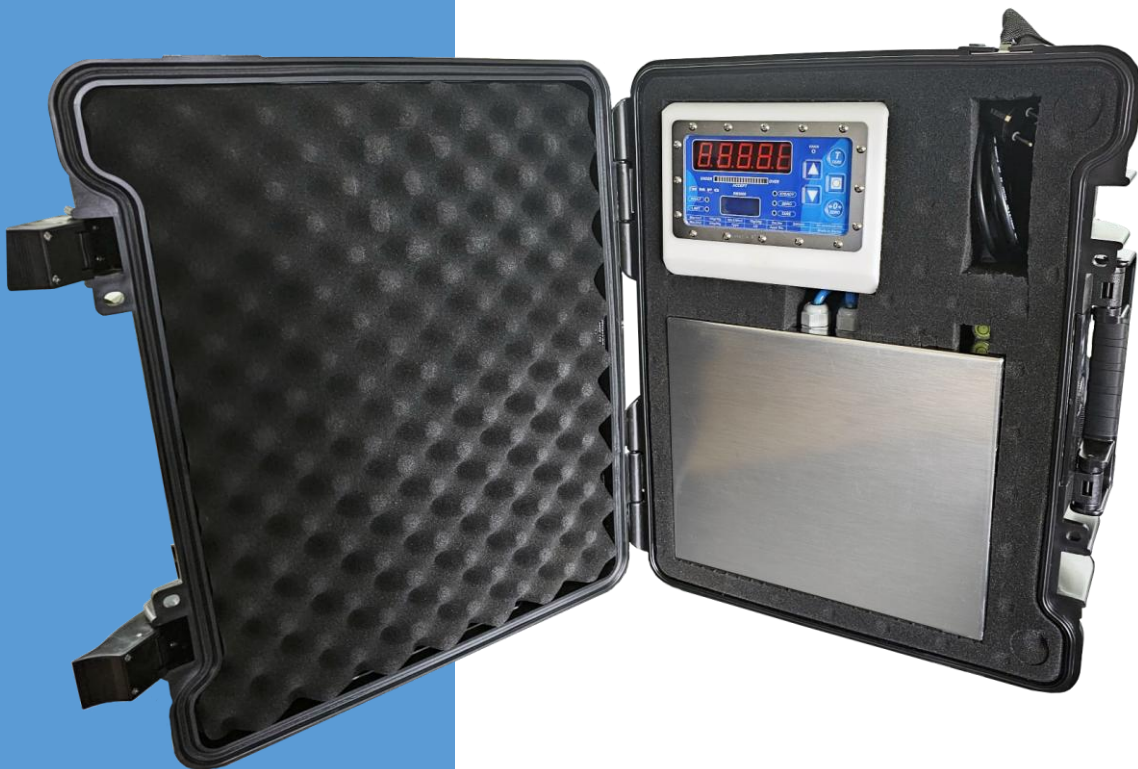

223, Gamcheonhang-ro, Saha-gu, Busan, South Korea, 49454

Fax: +82-51-2638-940

E-mail: [noatek1@gmail.com](mailto:noatek1@gmail.com)

CEO KIM A.B.

Phone: +82-10-5049-4892

## Technical data

OEM	RM Pusan Group
Equipment	Designed for weighing products. Consists of two components: weighing platform and indicator
Measuring range	0-20 kg
Frame material	Stainless steel, plastic
Connection to power supply	85-264V 50 Hz
Dimensions of the weighing platform	
Length	300 mm
Width	277 mm
Height	93 mm
Dimensions of indicator	
Length	222 mm
Width	137 mm
Height	150 mm
Weight specifications	
Weighing platform	7.8 kg
Indicator	1.7kg
Weight in package	15.5 kg

---

### Dimension drawing

Dimensional drawing of the weighing platform

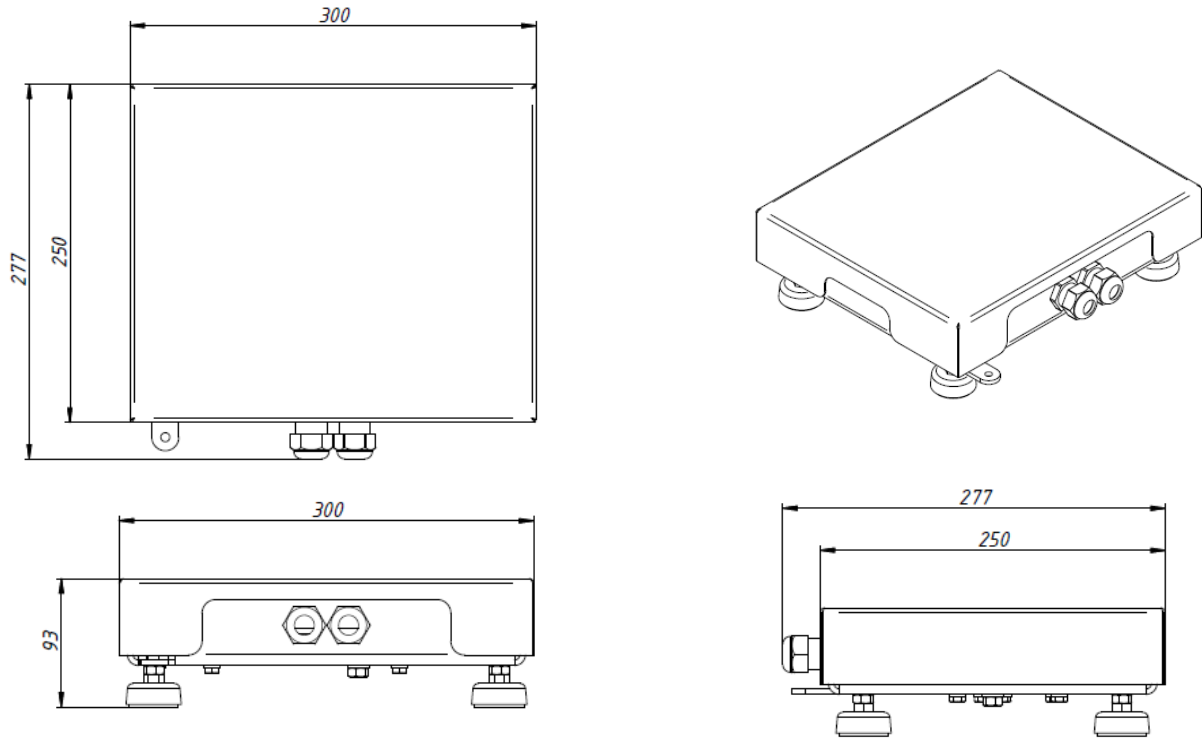

Dimensional drawing of indicator

