

RM 195HRF-A

FILLETING COMPLEX
FOR FILLETING
HERRING AND
SMALL POLLACK
WITH AUTOMATIC FEEDER
RM180

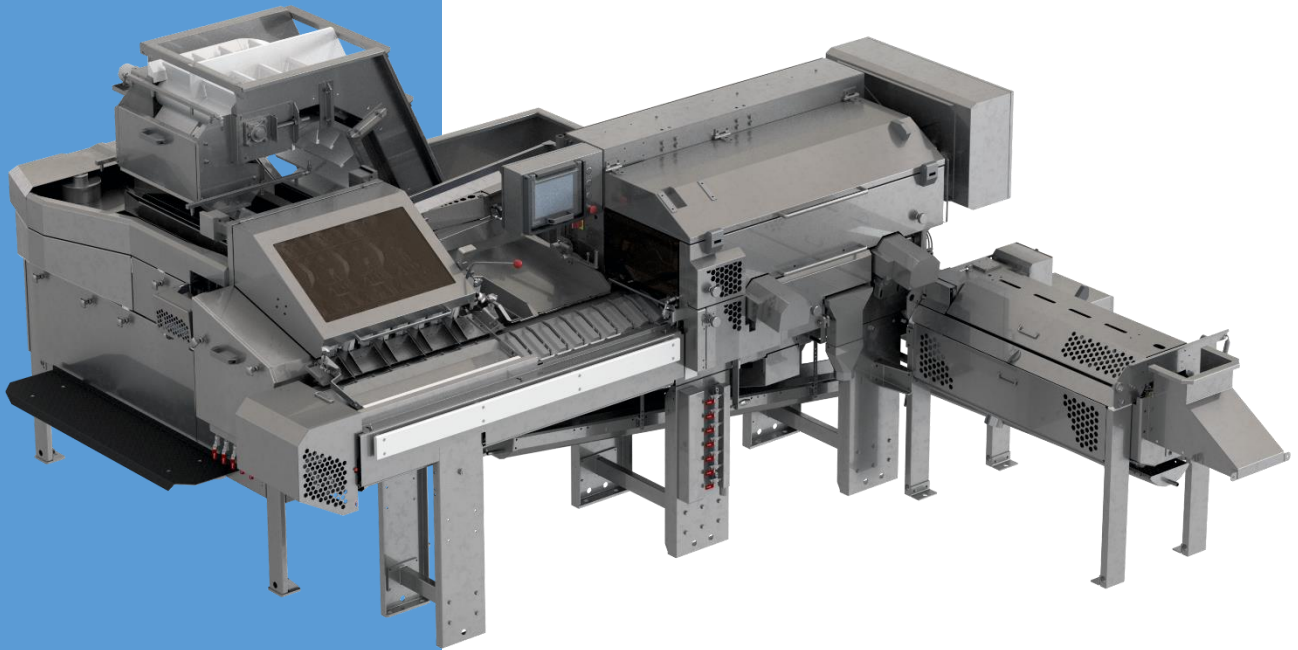

223, Gamcheonhang-ro, Saha-gu, Busan, South Korea, 49454
Fax: +82-51-2638-940
E-mail: noatek1@gmail.com
CEO Kim Aleksey

Technical data

OEM	RMPusan Group
Equipment	the machine is used for production of herring fillets called “butterfly” and small pollock (25–43 cm)
Throughput rate*: for herring for pollock	up 22 to 40 cm at speeds up to 320 fish/min up 25 to 43 cm at speeds up to 160 fish/min
Frame material	Stainless steel 304
Power consumption	10.5 kW
Electrical connection	3 Ph 380V/460V AC 50/60 Hz
Industrial water	
Consumption	up to 100 l / min
Pressure	3–6 bar
Connection	3 x 1" (Hbse inner diameter)
Dimensions of the machine	
Length	4400 mm
Width	4500 mm
Height	2300 mm
Weight	about 2560 kg

Note:

* - throughput rate depends on the size of the raw fish

Rawfish..... Processing End-product

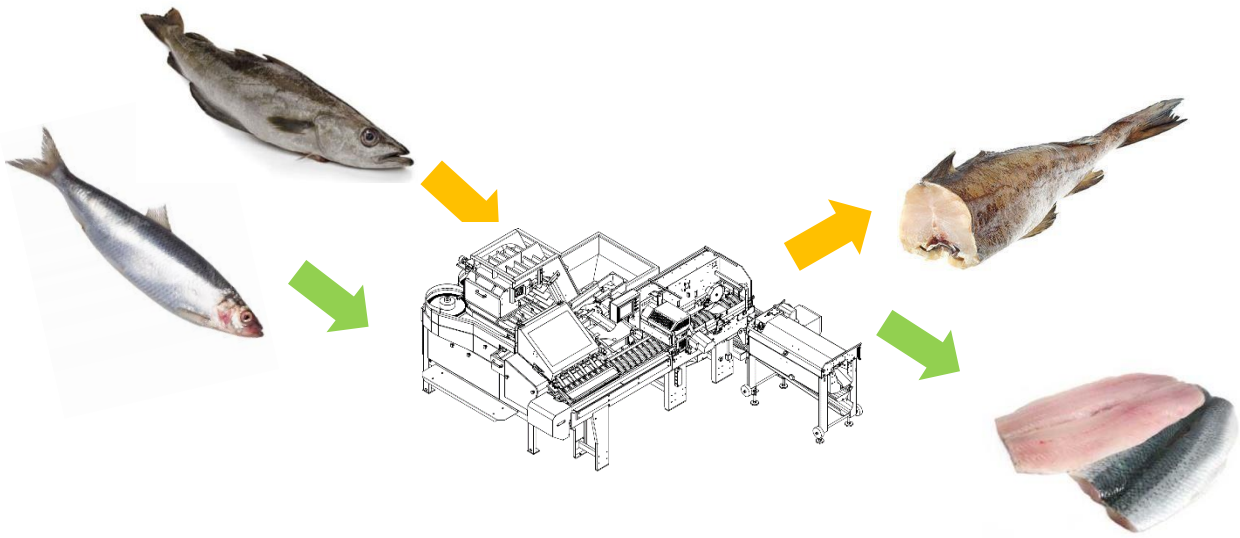

Dimensional drawing

