

RM 195 HR

HEAD CUTTING AND
GUTTING MACHINE FOR
HERRING AND SMALL
POLLACK

Technical data

OEM	RM Pusan Group
	Designed for the production of gutted herring and small pollack without head with size from 25 to 43 cm.
Throughput rate*:	
for herring	up 22 to 40 cm at speeds up to 180 fish/min.
for pollack	up 25 to 43 cm at speeds up to 160 fish/min.
Frame material	Stainless steel
Power consumption	2.3 kW
Connection to power supply	380V/460V 3 phase 50/60 Hz
Industrial water	
Flow rate	up to 35 l/min
Pressure	3-6 bar
Connection	1" (hose inner diameter)
Dimensions of the machine	
Length	4070 mm
Width	1325 mm
Height	1855 mm
Weight	950 kg

* - throughput rate depends on raw material size

Raw fish..... Processing..... End-product

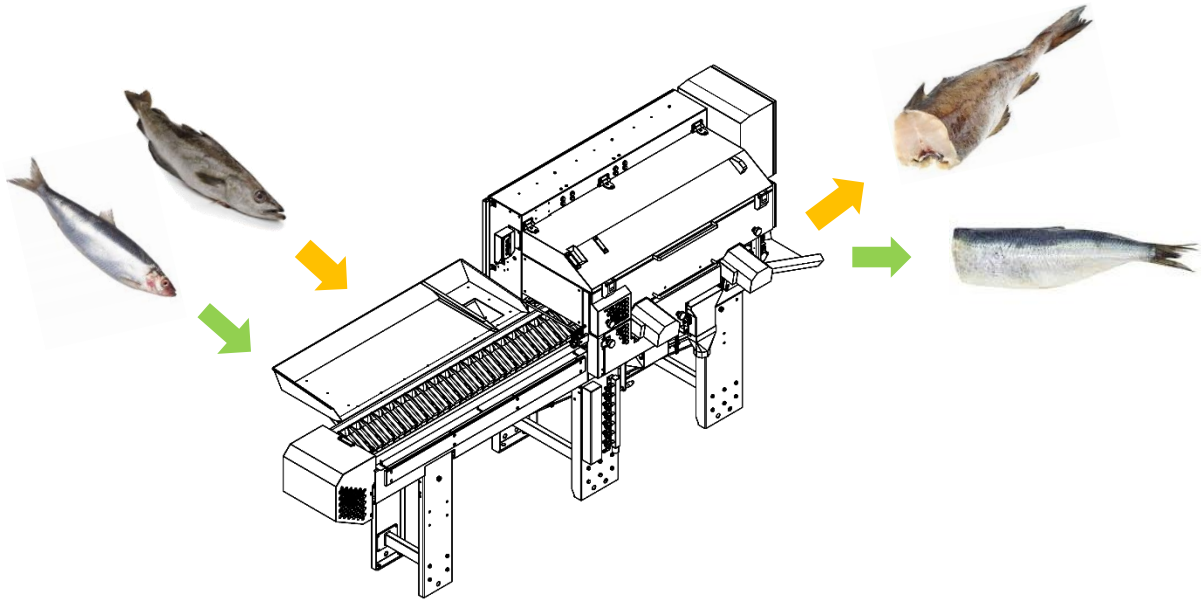

Dimension drawing

