

RM 141

Automatic block
ejector

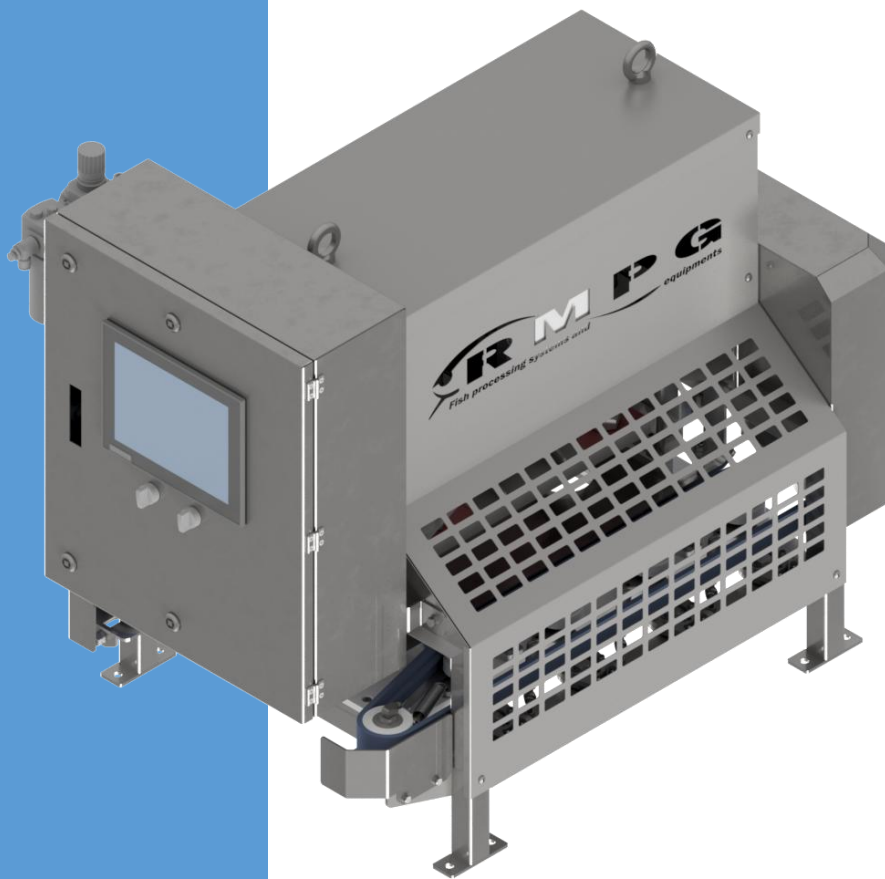

223, Gamcheonhang-ro, Saha-gu, Busan, South Korea, 49454

Fax: +82-51-2638-940

E-mail: noatek1@gmail.com

CEO KIM A.B.

Phone: +82-10-5049-4892

Technical data

OEM	RM Pusan Group
Equipment	Designed for automatic squeezing frozen fish from block molds
Throughput rate:	12 blocks / min
Frame material	Stainless steel 304
Belt drive	Electric
Drive of press plate and gate valves	Pneumatic
Pneumatic system pressure	7-9 kg/cm ²
Power consumption	0.75 kW
Connection to power supply	220V 2 phase 50/60 Hz
Dimensions of the machine	
Length	3550 mm
Width	1095 mm
Height	1485 mm
Weight	150 kg

Frozen fish in block form Squeezing Frozen fish

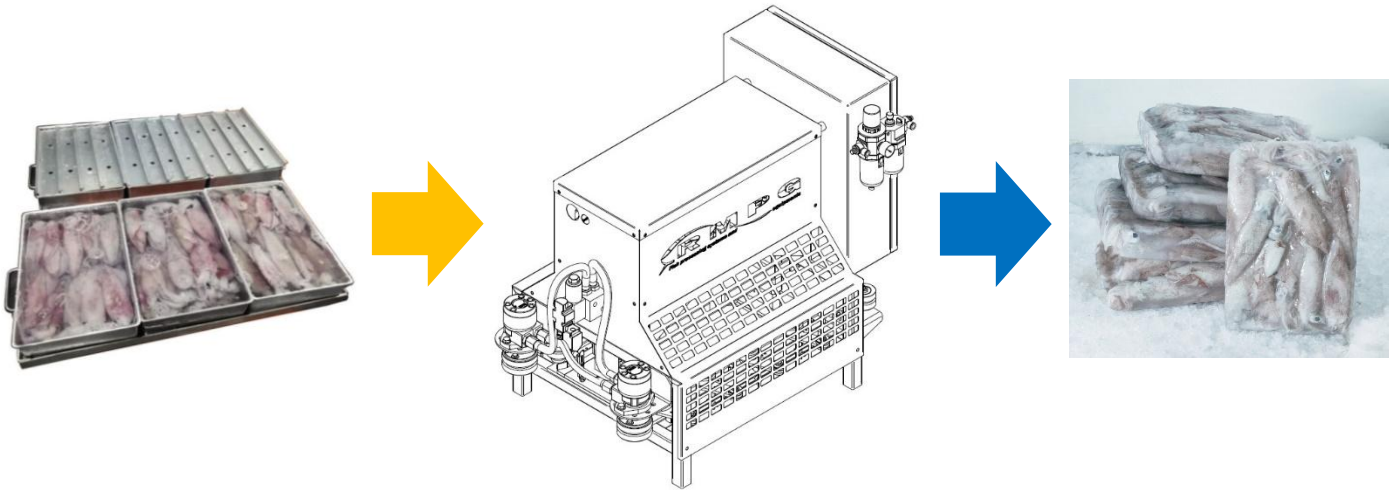

Dimension drawing

