

RM 120T

FISH MEAL PROCESSING

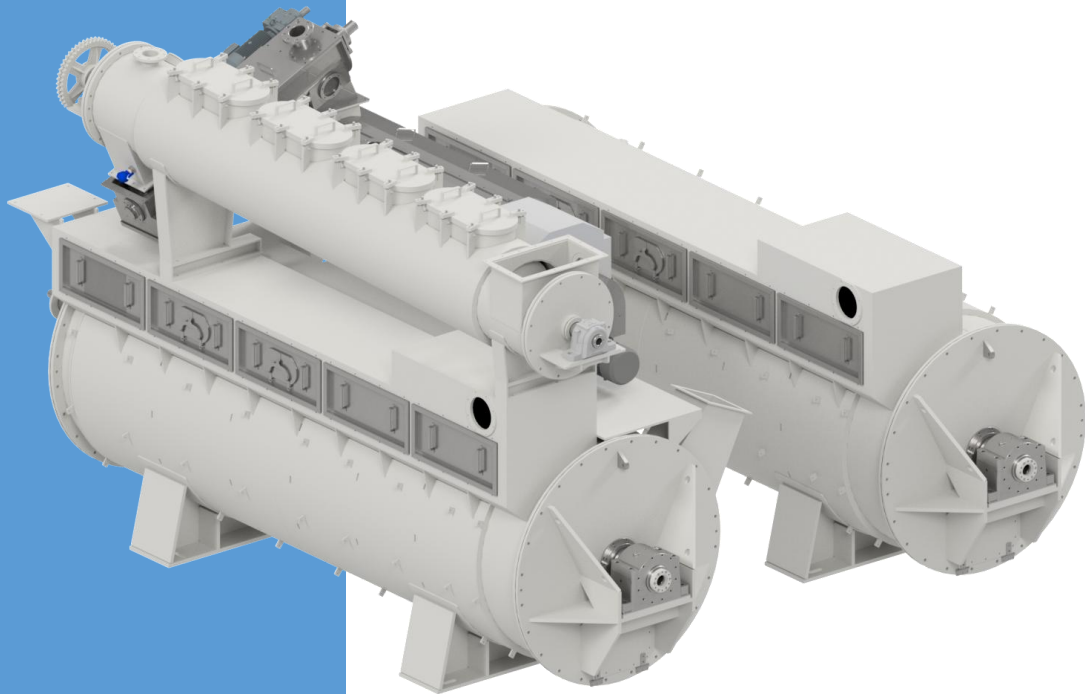

223, Gamcheonhang-ro, Saha-gu, Busan, South Korea, 49454

Fax: +82-51-2638-940

E-mail: noatek1@gmail.com

CEO KIM A.B.

Phone: +82-10-5049-4892

Technical data

OEM	RM Pusan Group
Equipment	The machine is using for the production of feed meal from fish waste and low-value fish species
Throughput rate	120 t/a day
Frame material	Boiler steel
Steam pressure requirement	7 bar
Power consumption	75 kWt
Electrical connection	3 Ph 380 VAC 50/60Hz
Dimensions of the machine	
Length	6335 mm
Width	4917 mm
Height	3443 mm
Weight	45 t

RM fish meal lines also includes models with throughput rate up to 30, 50 and 80 t / a day

Raw materials.....Processing.....End-product

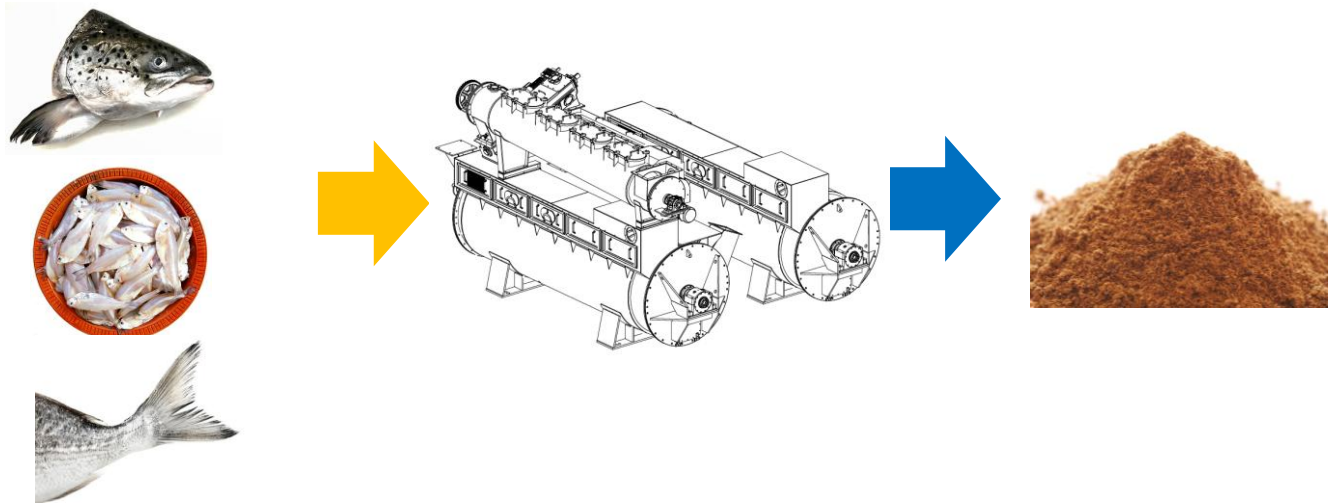

Dimensional drawing

